

# Surgical Saw Blades

## CATALOGUE

Accessible and Reliable

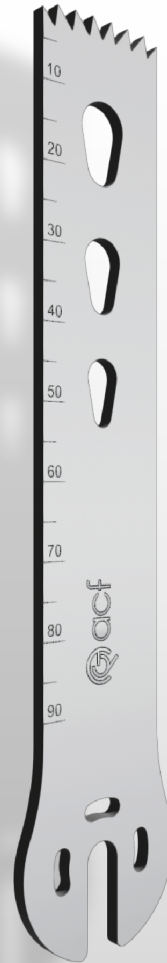



# Saw Blades Compatible with CONMED LINVATEC®



Brand Code **140**

For Reciprocating Saws and Some Micro Blades  
**100**

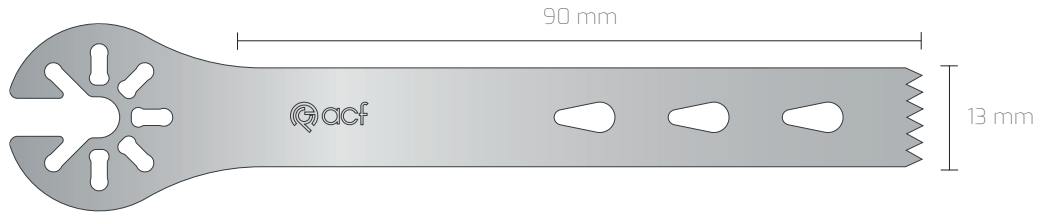

NON-STERILE REF	STERILE REF	Cutting Edge	Cutting Depth	Material Thickness	Cutting Thickness	Teeth
140 130 090 089	S 140 130 090 089	13 mm	90 mm	0,89 mm	0,89 mm	Straight
140 130 090 090	S 140 130 090 090	13 mm	90 mm	0,90 mm	0,90 mm	Straight
140 130 090 100	S 140 130 090 100	13 mm	90 mm	1,00 mm	1,00 mm	Straight
140 130 090 119	S 140 130 090 119	13 mm	90 mm	1,19 mm	1,19 mm	Straight
140 130 090 120	S 140 130 090 120	13 mm	90 mm	1,20 mm	1,20 mm	Straight
140 130 090 127	S 140 130 090 127	13 mm	90 mm	1,27 mm	1,27 mm	Straight
140 130 090 130	S 140 130 090 130	13 mm	90 mm	1,30 mm	1,30 mm	Straight
140 130 090 137	S 140 130 090 137	13 mm	90 mm	1,37 mm	1,37 mm	Straight
140 130 090 140	S 140 130 090 140	13 mm	90 mm	1,40 mm	1,40 mm	Straight
140 130 090 147	S 140 130 090 147	13 mm	90 mm	1,47 mm	1,47 mm	Straight
140 130 090 150	S 140 130 090 150	13 mm	90 mm	1,50 mm	1,50 mm	Straight

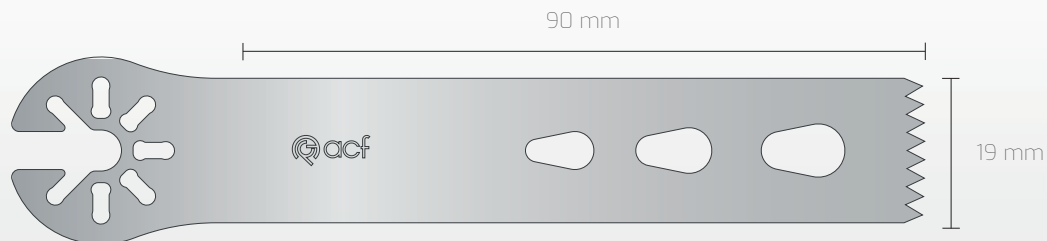

NON-STERILE REF	STERILE REF	Cutting Edge	Cutting Depth	Material Thickness	Cutting Thickness	Teeth
140 190 090 089	S 140 190 090 089	19 mm	90 mm	0,89 mm	0,89 mm	Straight
140 190 090 090	S 140 190 090 090	19 mm	90 mm	0,90 mm	0,90 mm	Straight
140 190 090 100	S 140 190 090 100	19 mm	90 mm	1,00 mm	1,00 mm	Straight
140 190 090 119	S 140 190 090 119	19 mm	90 mm	1,19 mm	1,19 mm	Straight
140 190 090 120	S 140 190 090 120	19 mm	90 mm	1,20 mm	1,20 mm	Straight
140 190 090 127	S 140 190 090 127	19 mm	90 mm	1,27 mm	1,27 mm	Straight
140 190 090 130	S 140 190 090 130	19 mm	90 mm	1,30 mm	1,30 mm	Straight
140 190 090 137	S 140 190 090 137	19 mm	90 mm	1,37 mm	1,37 mm	Straight
140 190 090 140	S 140 190 090 140	19 mm	90 mm	1,40 mm	1,40 mm	Straight
140 190 090 147	S 140 190 090 147	19 mm	90 mm	1,47 mm	1,47 mm	Straight
140 190 090 150	S 140 190 090 150	19 mm	90 mm	1,50 mm	1,50 mm	Straight

**Compatible Connections;**

M Power PRO6300, M Power2 PRO6350M, PowerPro Max PRO5300M, PowerPro Electric II PRO6125, PowerPro Pneumatic PRO6175, Hall 4 5067-002, Hall 3 5044-002, Versipower Plus 5071-002, Hall 50 PRO7300B

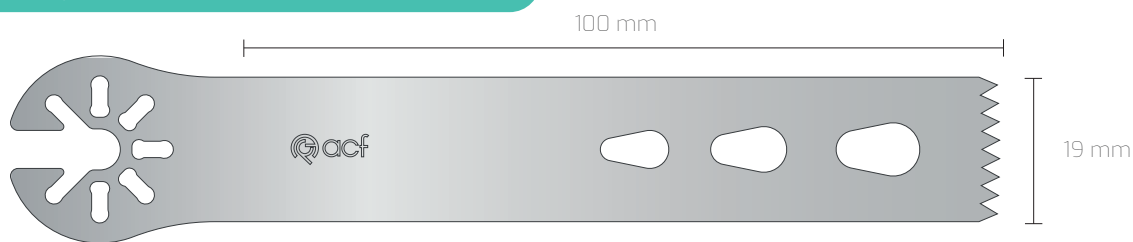

NON-STERILE REF	STERILE REF	Cutting Edge	Cutting Depth	Material Thickness	Cutting Thickness	Teeth
140 190 100 089	S 140 190 100 089	19 mm	100 mm	0,89 mm	0,89 mm	Straight
140 190 100 090	S 140 190 100 090	19 mm	100 mm	0,90 mm	0,90 mm	Straight
140 190 100 100	S 140 190 100 100	19 mm	100 mm	1,00 mm	1,00 mm	Straight
140 190 100 119	S 140 190 100 119	19 mm	100 mm	1,19 mm	1,19 mm	Straight
140 190 100 120	S 140 190 100 120	19 mm	100 mm	1,20 mm	1,20 mm	Straight
140 190 100 127	S 140 190 100 127	19 mm	100 mm	1,27 mm	1,27 mm	Straight
140 190 100 130	S 140 190 100 130	19 mm	100 mm	1,30 mm	1,30 mm	Straight
140 190 100 137	S 140 190 100 137	19 mm	100 mm	1,37 mm	1,37 mm	Straight
140 190 100 140	S 140 190 100 140	19 mm	100 mm	1,40 mm	1,40 mm	Straight
140 190 100 147	S 140 190 100 147	19 mm	100 mm	1,47 mm	1,47 mm	Straight
140 190 100 150	S 140 190 100 150	19 mm	100 mm	1,50 mm	1,50 mm	Straight

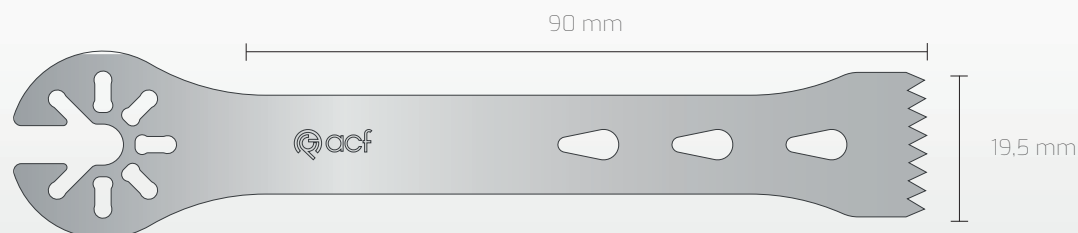

NON-STERILE REF	STERILE REF	Cutting Edge	Cutting Depth	Material Thickness	Cutting Thickness	Teeth
140 195 090 089	S 140 195 090 089	19,5 mm	90 mm	0,89 mm	0,89 mm	Straight
140 195 090 090	S 140 195 090 090	19,5 mm	90 mm	0,90 mm	0,90 mm	Straight
140 195 090 100	S 140 195 090 100	19,5 mm	90 mm	1,00 mm	1,00 mm	Straight
140 195 090 119	S 140 195 090 119	19,5 mm	90 mm	1,19 mm	1,19 mm	Straight
140 195 090 120	S 140 195 090 120	19,5 mm	90 mm	1,20 mm	1,20 mm	Straight
140 195 090 127	S 140 195 090 127	19,5 mm	90 mm	1,27 mm	1,27 mm	Straight
140 195 090 130	S 140 195 090 130	19,5 mm	90 mm	1,30 mm	1,30 mm	Straight
140 195 090 137	S 140 195 090 137	19,5 mm	90 mm	1,37 mm	1,37 mm	Straight
140 195 090 140	S 140 195 090 140	19,5 mm	90 mm	1,40 mm	1,40 mm	Straight
140 195 090 147	S 140 195 090 147	19,5 mm	90 mm	1,47 mm	1,47 mm	Straight
140 195 090 150	S 140 195 090 150	19,5 mm	90 mm	1,50 mm	1,50 mm	Straight

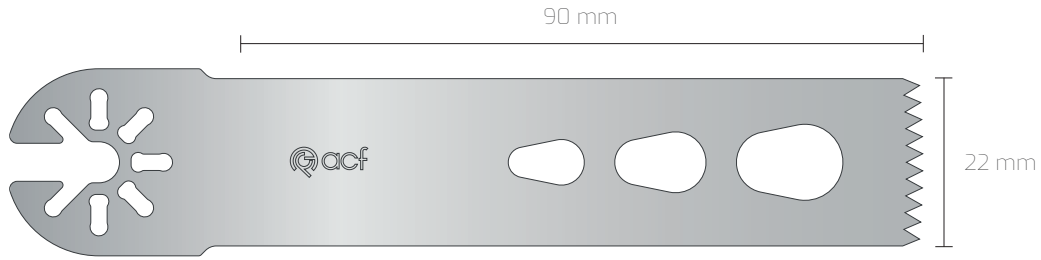

NON-STERILE REF	STERILE REF	Cutting Edge	Cutting Depth	Material Thickness	Cutting Thickness	Teeth
140 220 090 089	S 140 220 090 089	22 mm	90 mm	0,89 mm	0,89 mm	Straight
140 220 090 090	S 140 220 090 090	22 mm	90 mm	0,90 mm	0,90 mm	Straight
140 220 090 100	S 140 220 090 100	22 mm	90 mm	1,00 mm	1,00 mm	Straight
140 220 090 119	S 140 220 090 119	22 mm	90 mm	1,19 mm	1,19 mm	Straight
140 220 090 120	S 140 220 090 120	22 mm	90 mm	1,20 mm	1,20 mm	Straight
140 220 090 127	S 140 220 090 127	22 mm	90 mm	1,27 mm	1,27 mm	Straight
140 220 090 130	S 140 220 090 130	22 mm	90 mm	1,30 mm	1,30 mm	Straight
140 220 090 137	S 140 220 090 137	22 mm	90 mm	1,37 mm	1,37 mm	Straight
140 220 090 140	S 140 220 090 140	22 mm	90 mm	1,40 mm	1,40 mm	Straight
140 220 090 147	S 140 220 090 147	22 mm	90 mm	1,47 mm	1,47 mm	Straight
140 220 090 150	S 140 220 090 150	22 mm	90 mm	1,50 mm	1,50 mm	Straight

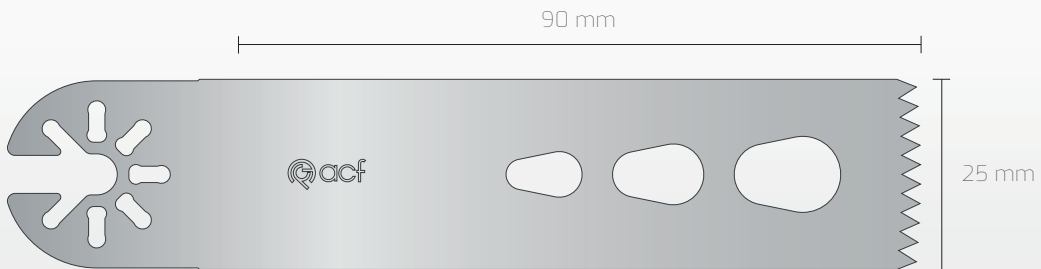

NON-STERILE REF	STERILE REF	Cutting Edge	Cutting Depth	Material Thickness	Cutting Thickness	Teeth
140 250 090 089	S 140 250 090 089	25 mm	90 mm	0,89 mm	0,89 mm	Straight
140 250 090 090	S 140 250 090 090	25 mm	90 mm	0,90 mm	0,90 mm	Straight
140 250 090 100	S 140 250 090 100	25 mm	90 mm	1,00 mm	1,00 mm	Straight
140 250 090 119	S 140 250 090 119	25 mm	90 mm	1,19 mm	1,19 mm	Straight
140 250 090 120	S 140 250 090 120	25 mm	90 mm	1,20 mm	1,20 mm	Straight
140 250 090 127	S 140 250 090 127	25 mm	90 mm	1,27 mm	1,27 mm	Straight
140 250 090 130	S 140 250 090 130	25 mm	90 mm	1,30 mm	1,30 mm	Straight
140 250 090 137	S 140 250 090 137	25 mm	90 mm	1,37 mm	1,37 mm	Straight
140 250 090 140	S 140 250 090 140	25 mm	90 mm	1,40 mm	1,40 mm	Straight
140 250 090 147	S 140 250 090 147	25 mm	90 mm	1,47 mm	1,47 mm	Straight
140 250 090 150	S 140 250 090 150	25 mm	90 mm	1,50 mm	1,50 mm	Straight

**Compatible Connections;**

M Power PRO6300, M Power2 PRO6350M, PowerPro Max PRO5300M, PowerPro Electric II PRO6125, PowerPro Pneumatic PRO6175, Hall 4 5067-002, Hall 3 5044-002, Versipower Plus 5071-002, Hall 50 PRO7300B

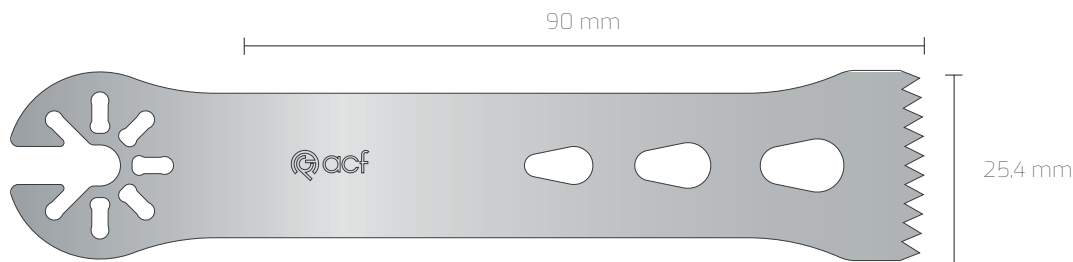

NON-STERILE REF	STERILE REF	Cutting Edge	Cutting Depth	Material Thickness	Cutting Thickness	Teeth
140 254 090 089	S 140 254 090 089	25,4 mm	90 mm	0,89 mm	0,89 mm	Straight
140 254 090 090	S 140 254 090 090	25,4 mm	90 mm	0,90 mm	0,90 mm	Straight
140 254 090 100	S 140 254 090 100	25,4 mm	90 mm	1,00 mm	1,00 mm	Straight
140 254 090 119	S 140 254 090 119	25,4 mm	90 mm	1,19 mm	1,19 mm	Straight
140 254 090 120	S 140 254 090 120	25,4 mm	90 mm	1,20 mm	1,20 mm	Straight
140 254 090 127	S 140 254 090 127	25,4 mm	90 mm	1,27 mm	1,27 mm	Straight
140 254 090 130	S 140 254 090 130	25,4 mm	90 mm	1,30 mm	1,30 mm	Straight
140 254 090 137	S 140 254 090 137	25,4 mm	90 mm	1,37 mm	1,37 mm	Straight
140 254 090 140	S 140 254 090 140	25,4 mm	90 mm	1,40 mm	1,40 mm	Straight
140 254 090 147	S 140 254 090 147	25,4 mm	90 mm	1,47 mm	1,47 mm	Straight
140 254 090 150	S 140 254 090 150	25,4 mm	90 mm	1,50 mm	1,50 mm	Straight

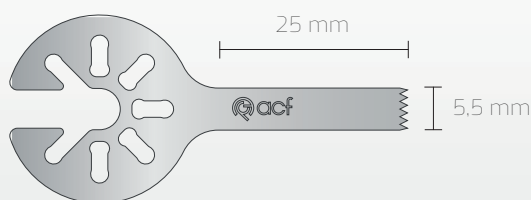

NON-STERILE REF	STERILE REF	Cutting Edge	Cutting Depth	Material Thickness	Cutting Thickness	Teeth
140 055 025 060	S 140 055 025 060	5,5 mm	25 mm	0,60 mm	0,60 mm	Straight
140 055 025 080	S 140 055 025 080	5,5 mm	25 mm	0,80 mm	0,80 mm	Straight

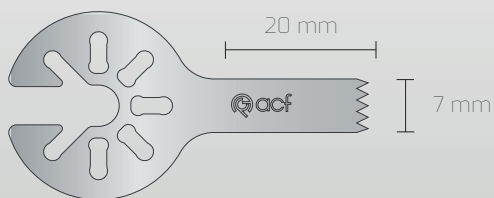

NON-STERILE REF	STERILE REF	Cutting Edge	Cutting Depth	Material Thickness	Cutting Thickness	Teeth
140 070 020 080	S 140 070 020 080	7 mm	20 mm	0,80 mm	0,80 mm	Straight

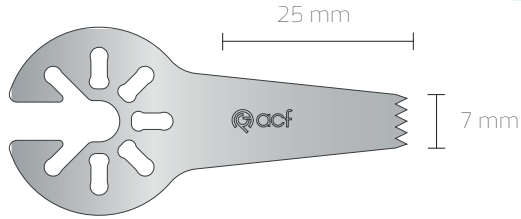

NON-STERILE REF	STERILE REF	Cutting Edge	Cutting Depth	Material Thickness	Cutting Thickness	Teeth
140 070 025 060	S 140 070 025 060	7 mm	25 mm	0,60 mm	0,60 mm	Straight
X 140 070 025 060	SX 140 070 025 060	7 mm	25 mm	0,60 mm	0,80 mm	Cross

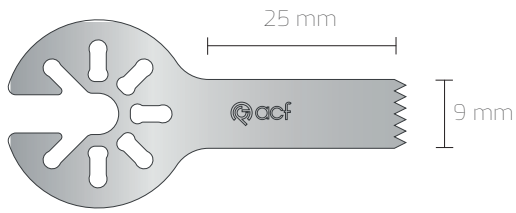

NON-STERILE REF	STERILE REF	Cutting Edge	Cutting Depth	Material Thickness	Cutting Thickness	Teeth
140 090 025 060	S 140 090 025 060	9 mm	25 mm	0,60 mm	0,60 mm	Straight
X 140 090 025 060	SX 140 090 025 060	9 mm	25 mm	0,60 mm	0,80 mm	Cross
140 090 025 090	S 140 090 025 090	9 mm	25 mm	0,90 mm	0,90 mm	Straight

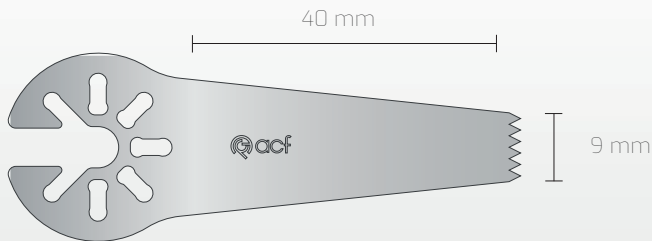

NON-STERILE REF	STERILE REF	Cutting Edge	Cutting Depth	Material Thickness	Cutting Thickness	Teeth
140 090 040 060	S 140 090 040 060	9 mm	40 mm	0,60 mm	0,60 mm	Straight
X 140 090 040 060	SX 140 090 040 060	9 mm	40 mm	0,60 mm	0,80 mm	Cross

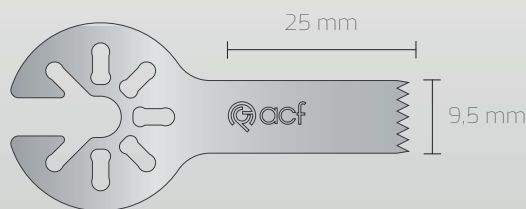

NON-STERILE REF	STERILE REF	Cutting Edge	Cutting Depth	Material Thickness	Cutting Thickness	Teeth
140 095 025 060	S 140 095 025 060	9,5 mm	25 mm	0,60 mm	0,60 mm	Straight

**Compatible Connections;**

M Power PRO6300, M Power2 PRO6350M, PowerPro Max PRO5300M, PowerPro Electric II PRO6125, PowerPro Pneumatic PRO6175, Hall 4 5067-002, Hall 3 5044-002, Versipower Plus 5071-002, Hall 50 PRO7300B

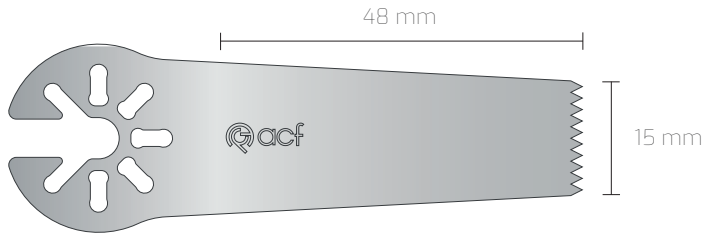

NON-STERILE REF	STERILE REF	Cutting Edge	Cutting Depth	Material Thickness	Cutting Thickness	Teeth
140 150 048 060	S 140 150 048 060	15 mm	48 mm	0,60 mm	0,60 mm	Straight
X 140 150 048 060	SX 140 150 048 060	15 mm	48 mm	0,60 mm	0,80 mm	Cross

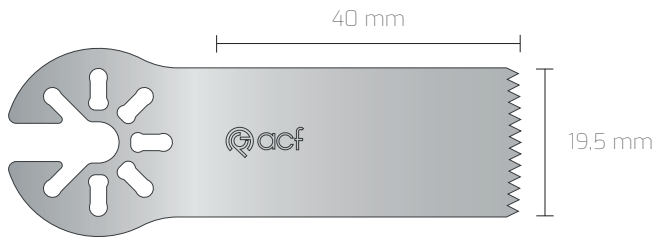

NON-STERILE REF	STERILE REF	Cutting Edge	Cutting Depth	Material Thickness	Cutting Thickness	Teeth
140 195 040 060	S 140 195 040 060	19,5 mm	40 mm	0,60 mm	0,60 mm	Straight
X 140 195 040 060	SX 140 195 040 060	19,5 mm	40 mm	0,60 mm	0,80 mm	Cross

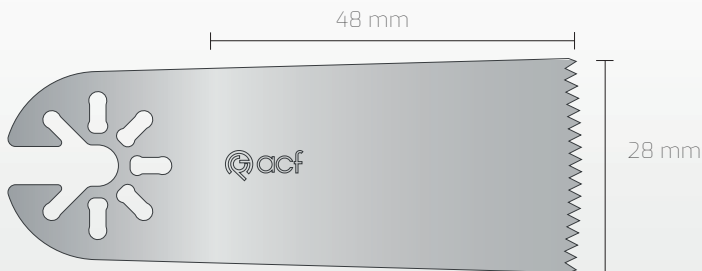

NON-STERILE REF	STERILE REF	Cutting Edge	Cutting Depth	Material Thickness	Cutting Thickness	Teeth
140 280 048 060	S 140 280 048 060	28 mm	48 mm	0,60 mm	0,60 mm	Straight
X 140 280 048 060	SX 140 280 048 060	28 mm	48 mm	0,60 mm	0,80 mm	Cross

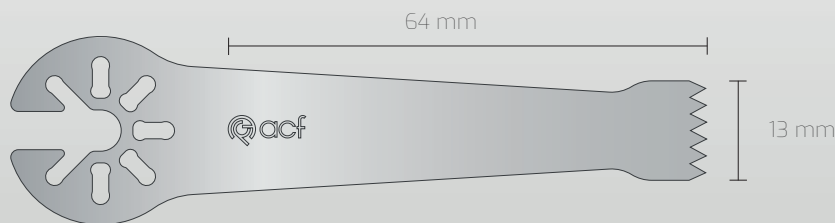

NON-STERILE REF	STERILE REF	Cutting Edge	Cutting Depth	Material Thickness	Cutting Thickness	Teeth
140 130 064 090	S 140 130 064 090	13 mm	64 mm	0,90 mm	0,90 mm	Straight



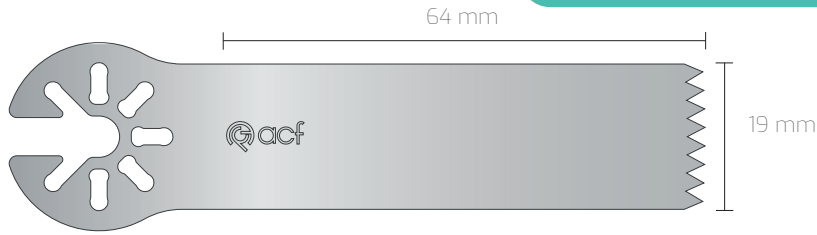

NON-STERILE REF	STERILE REF	Cutting Edge	Cutting Depth	Material Thickness	Cutting Thickness	Teeth
140 190 064 090	S 140 190 064 090	19 mm	64 mm	0,90 mm	0,90 mm	Straight



NON-STERILE REF	STERILE REF	Cutting Edge	Cutting Depth	Material Thickness	Cutting Thickness	Teeth
140 250 064 090	S 140 250 064 090	25 mm	64 mm	0,90 mm	0,90 mm	Straight

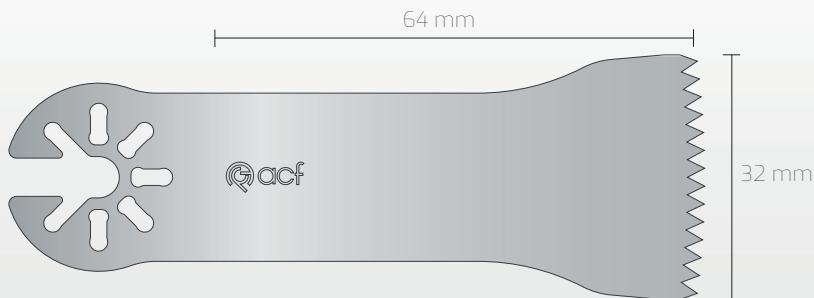

NON-STERILE REF	STERILE REF	Cutting Edge	Cutting Depth	Material Thickness	Cutting Thickness	Teeth
140 320 064 090	S 140 320 064 090	32 mm	64 mm	0,90 mm	0,90 mm	Straight

**Compatible Connections;**

M Power PRO6300, M Power2 PRO6350M, PowerPro Max PRO5300M, PowerPro Electric II PRO6125, PowerPro Pneumatic PRO6175, Hall 4 5067-002, Hall 3 5044-002, Versipower Plus 5071-002, Hall 50 PRO7300B

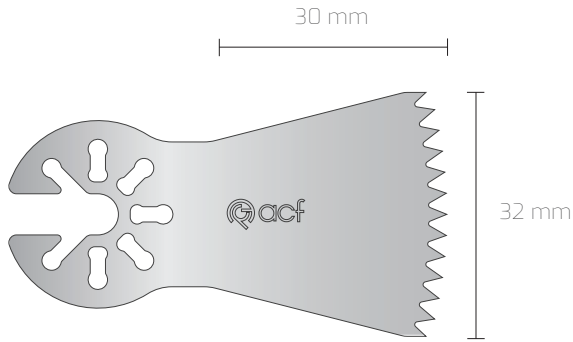

NON-STERILE REF	STERILE REF	Cutting Edge	Cutting Depth	Material Thickness	Cutting Thickness	Teeth
140 320 030 090	S 140 320 030 090	32 mm	30 mm	0,90 mm	0,90 mm	Straight

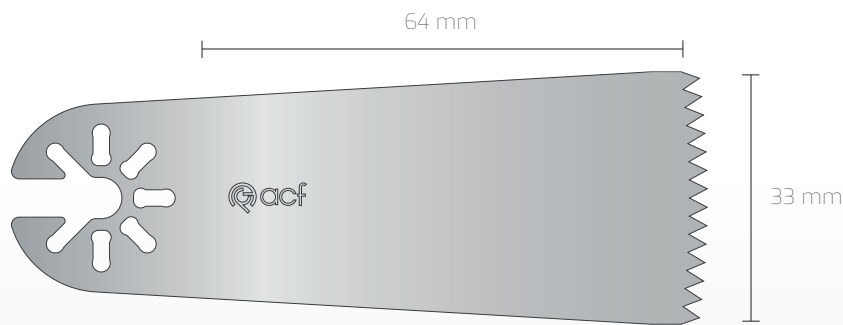

NON-STERILE REF	STERILE REF	Cutting Edge	Cutting Depth	Material Thickness	Cutting Thickness	Teeth
140 330 064 090	S 140 330 064 090	33 mm	64 mm	0,90 mm	0,90 mm	Straight

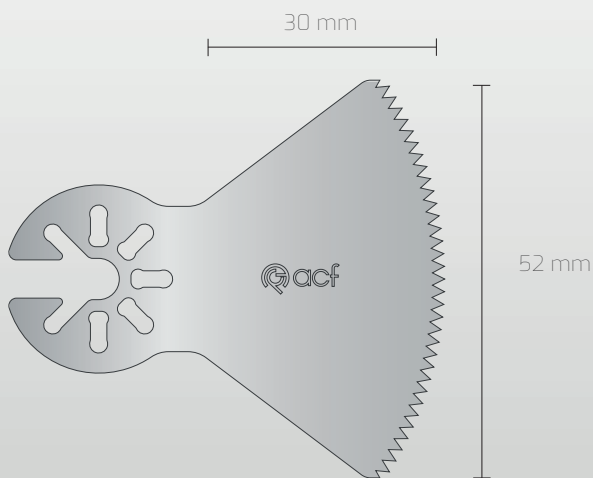

NON-STERILE REF	STERILE REF	Cutting Edge	Cutting Depth	Material Thickness	Cutting Thickness	Teeth
140 520 030 090	S 140 520 030 090	52 mm	30 mm	0,90 mm	0,90 mm	Straight

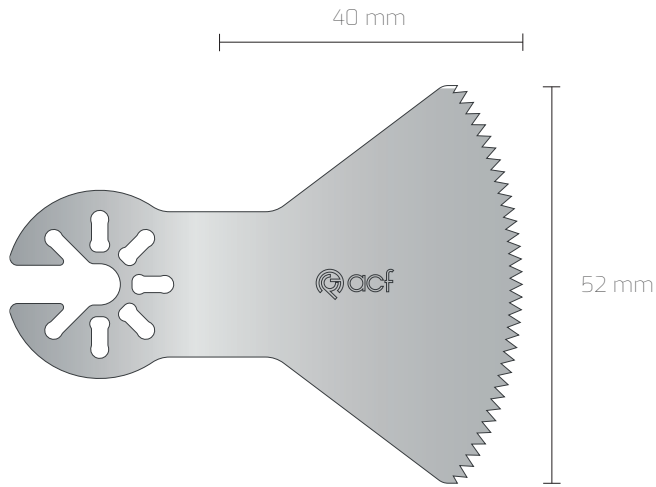

NON-STERILE REF	STERILE REF	Cutting Edge	Cutting Depth	Material Thickness	Cutting Thickness	Teeth
140 520 040 090	S 140 520 040 090	52 mm	40 mm	0,90 mm	0,90 mm	Straight

**Compatible Connections;**

PowerPro Pneumatic PRO6185, PowerPro Electric II PRO6135, PowerPro Max PRO5400M, MPower 2 PRO6400M, MPower PRO6400, Hall 4 5067-003, Hall 50 PRO7400B reciprocating saws

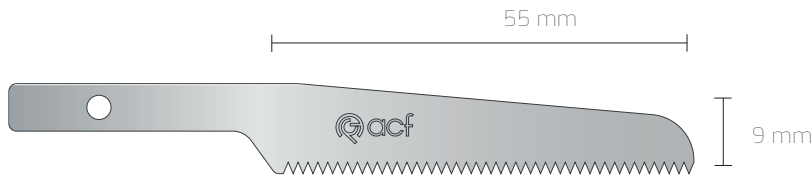

NON-STERILE REF	STERILE REF	Cutting Edge	Cutting Depth	Material Thickness	Cutting Thickness	Teeth
100 090 055 060	S 100 090 055 060	9 mm	55 mm	0,60 mm	0,60 mm	Straight
100 090 055 090	S 100 090 055 090	9 mm	55 mm	0,90 mm	0,90 mm	Straight
X 100 090 055 060	SX 100 090 055 060	9 mm	55 mm	0,60 mm	0,80 mm	Cross

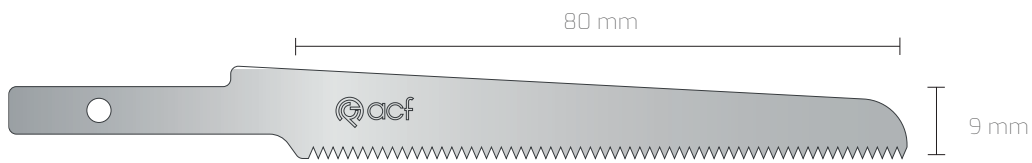

NON-STERILE REF	STERILE REF	Cutting Edge	Cutting Depth	Material Thickness	Cutting Thickness	Teeth
100 090 080 060	S 100 090 080 060	9 mm	80 mm	0,60 mm	0,60 mm	Straight
X 100 090 080 060	SX 100 090 080 060	9 mm	80 mm	0,60 mm	0,80 mm	Cross

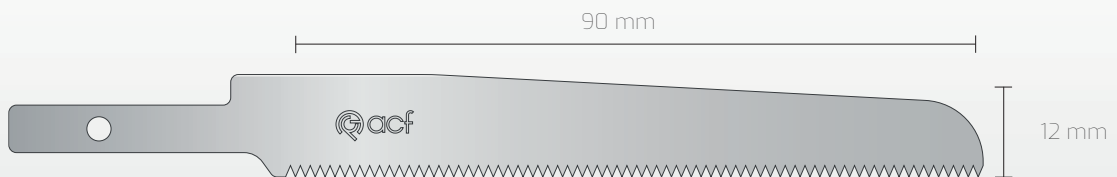

NON-STERILE REF	STERILE REF	Cutting Edge	Cutting Depth	Material Thickness	Cutting Thickness	Teeth
100 120 090 060	S 100 120 090 060	12 mm	90 mm	0,60 mm	0,60 mm	Straight
100 120 090 090	S 100 120 090 090	12 mm	90 mm	0,90 mm	0,90 mm	Straight
X 100 120 090 060	SX 100 120 090 060	12 mm	90 mm	0,60 mm	0,80 mm	Cross

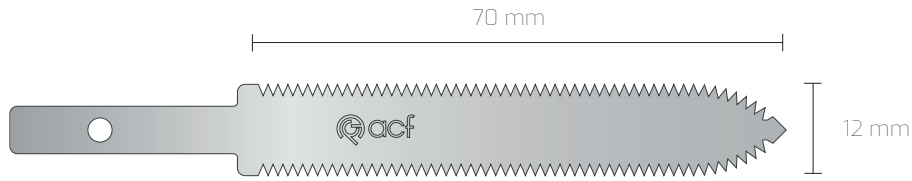

NON-STERILE REF	STERILE REF	Cutting Edge	Cutting Depth	Material Thickness	Cutting Thickness	Teeth
100 120 070 060	S 100 120 070 060	12 mm	70 mm	0,60 mm	0,60 mm	Straight
100 120 070 090	S 100 120 070 090	12 mm	70 mm	0,90 mm	0,90 mm	Straight
100 120 070 100	S 100 120 070 100	12 mm	70 mm	1,00 mm	1,00 mm	Straight
100 120 070 120	S 100 120 070 120	12 mm	70 mm	1,20 mm	1,20 mm	Straight
X 100 120 070 060	SX 100 120 070 060	12 mm	70 mm	0,60 mm	0,80 mm	Cross

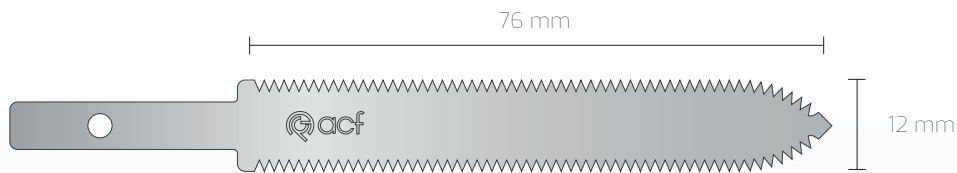

NON-STERILE REF	STERILE REF	Cutting Edge	Cutting Depth	Material Thickness	Cutting Thickness	Teeth
100 120 076 060	S 100 120 076 060	12 mm	76 mm	0,60 mm	0,60 mm	Straight
100 120 076 090	S 100 120 076 090	12 mm	76 mm	0,90 mm	0,90 mm	Straight
100 120 076 100	S 100 120 076 100	12 mm	76 mm	1,00 mm	1,00 mm	Straight
100 120 076 120	S 100 120 076 120	12 mm	76 mm	1,20 mm	1,20 mm	Straight
X 100 120 076 060	SX 100 120 076 060	12 mm	76 mm	0,60 mm	0,80 mm	Cross

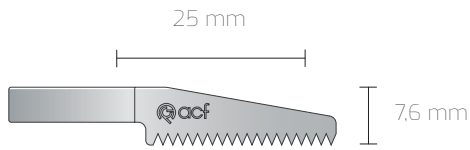

NON-STERILE REF	STERILE REF	Cutting Edge	Cutting Depth	Material Thickness	Cutting Thickness	Teeth
100 076 025 060	S 100 076 025 060	7,6 mm	25 mm	0,60 mm	0,60 mm	Straight
X 100 076 025 060	SX 100 076 025 060	7,6 mm	25 mm	0,60 mm	0,80 mm	Cross

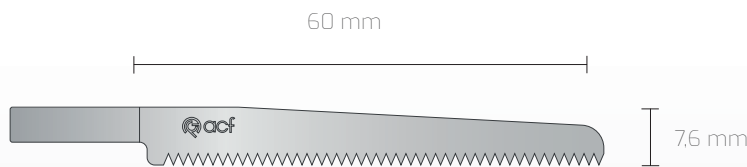

NON-STERILE REF	STERILE REF	Cutting Edge	Cutting Depth	Material Thickness	Cutting Thickness	Teeth
100 076 060 060	S 100 076 060 060	7,6 mm	60 mm	0,60 mm	0,60 mm	Straight

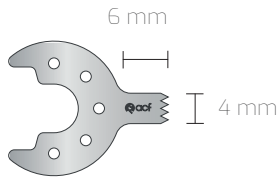

NON-STERILE REF	STERILE REF	Cutting Edge	Cutting Depth	Material Thickness	Cutting Thickness	Teeth
100 040 006 060	S 100 040 006 060	4 mm	6 mm	0,60 mm	0,60 mm	Straight

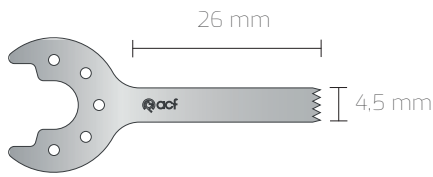

NON-STERILE REF	STERILE REF	Cutting Edge	Cutting Depth	Material Thickness	Cutting Thickness	Teeth
100 045 026 060	S 100 045 026 060	4,5 mm	26 mm	0,60 mm	0,60 mm	Straight

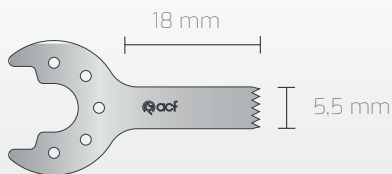

NON-STERILE REF	STERILE REF	Cutting Edge	Cutting Depth	Material Thickness	Cutting Thickness	Teeth
100 055 018 060	S 100 055 018 060	5,5 mm	18 mm	0,60 mm	0,60 mm	Straight

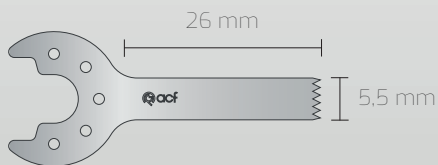

NON-STERILE REF	STERILE REF	Cutting Edge	Cutting Depth	Material Thickness	Cutting Thickness	Teeth
100 055 026 060	S 100 055 026 060	5,5 mm	26 mm	0,60 mm	0,60 mm	Straight

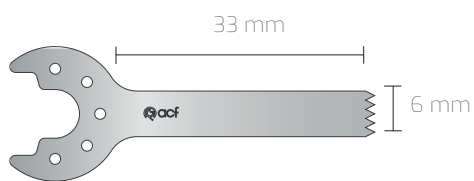

NON-STERILE REF	STERILE REF	Cutting Edge	Cutting Depth	Material Thickness	Cutting Thickness	Teeth
100 060 033 060	S 100 060 033 060	6 mm	33 mm	0,60 mm	0,60 mm	Straight

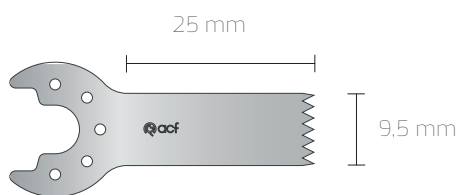

NON-STERILE REF	STERILE REF	Cutting Edge	Cutting Depth	Material Thickness	Cutting Thickness	Teeth
100 095 025 060	S 100 095 025 060	9,5 mm	25 mm	0,60 mm	0,60 mm	Straight

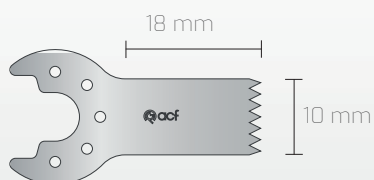

NON-STERILE REF	STERILE REF	Cutting Edge	Cutting Depth	Material Thickness	Cutting Thickness	Teeth
100 100 018 060	S 100 100 018 060	10 mm	18 mm	0,60 mm	0,60 mm	Straight
X 100 100 018 060	SX 100 100 018 060	10 mm	18 mm	0,60 mm	0,80 mm	Cross



NON-STERILE REF	STERILE REF	Cutting Edge	Cutting Depth	Material Thickness	Cutting Thickness	Teeth
100 100 030 060	S 100 100 030 060	10 mm	30 mm	0,60 mm	0,60 mm	Straight
X 100 100 030 060	SX 100 100 030 060	10 mm	30 mm	0,60 mm	0,80 mm	Cross



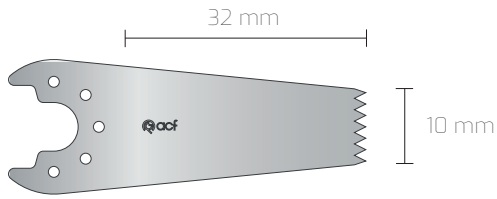

NON-STERILE REF	STERILE REF	Cutting Edge	Cutting Depth	Material Thickness	Cutting Thickness	Teeth
100 100 032 060	S 100 100 032 060	10 mm	32 mm	0,60 mm	0,60 mm	Straight
X 100 100 032 060	SX 100 100 032 060	10 mm	32 mm	0,60 mm	0,80 mm	Cross

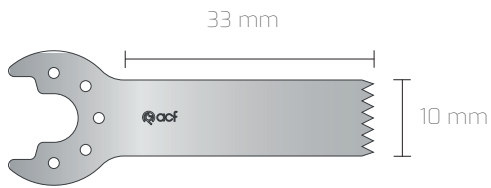

NON-STERILE REF	STERILE REF	Cutting Edge	Cutting Depth	Material Thickness	Cutting Thickness	Teeth
100 100 033 060	S 100 100 033 060	10 mm	33 mm	0,60 mm	0,60 mm	Straight
X 100 100 033 060	SX 100 100 033 060	10 mm	33 mm	0,60 mm	0,80 mm	Cross

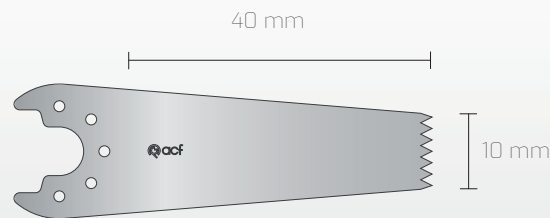

NON-STERILE REF	STERILE REF	Cutting Edge	Cutting Depth	Material Thickness	Cutting Thickness	Teeth
100 100 040 060	S 100 100 040 060	10 mm	40mm	0,60 mm	0,60 mm	Straight

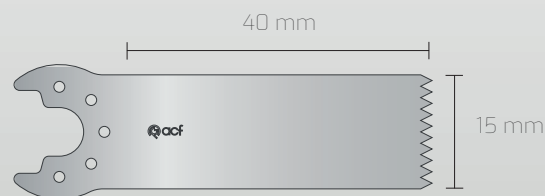

NON-STERILE REF	STERILE REF	Cutting Edge	Cutting Depth	Material Thickness	Cutting Thickness	Teeth
100 150 040 060	S 100 150 040 060	15 mm	40 mm	0,60 mm	0,60 mm	Straight
X 100 150 040 060	SX 100 150 040 060	15 mm	40 mm	0,60 mm	0,80 mm	Cross



---

ACF Medikal Urunler Mak. San. ve Tic. Ltd. Sti.

Guzelyurt Mah. 5754 Sok. No: 3/A  
Yunusemre / Manisa, Turkey, 45030

+90 236 236 28 20

info@acf.com.tr

[www.acf.com.tr](http://www.acf.com.tr)